

UC160-190

Ultra Compact Series - The Smallest Recirculating Chiller on the Planet



Product Manual

TABLE OF CONTENTS

SAFETY PRECAUTIONS AND SYMBOLS	3
SECTION 1	4
INTRODUCTION	4
SECTION 2	5
SPECIFICATIONS	5
SECTION 3	7
HOOK UP	7
3.1 ELECTRICAL CONNECTIONS (SEE FIGURES 3A AND 3B)	8
3.2 PLUMBING CONNECTIONS (SEE FIGURE 3A AND 3B)	9
3.3 AIR CONSIDERATIONS	9
3.4 COOLANT FILL	9
3.5 PRIMING THE PUMP	10
SECTION 4	11
START UP	11
SECTION 5	12
OPERATION	12
5.1 SIMPLE OPERATION	12
5.2 ADVANCED OPERATION	12
5.3 ALARM SIGNAL	14
SECTION 6	16
SYSTEM ALARMS/TROUBLESHOOTING	16
SECTION 7	17
RS-232 COMMUNICATION	17
7.1 COMMUNICATION SPECIFICATION	17
7.2 COMMUNICATION PROTOCOL	18
7.3 RS232 COMMUNICATION EXAMPLES	20
SECTION 8	20
TECHNICAL SUPPORT	20
SECTION 9	21
SDS FOR COOLANTS	21
9.1 KOOLANCE (27% PROPYLENE GLYCOL/WATER)	21
9.2 ETHYLENE GLYCOL	26
WARRANTY POLICY	33



CE Declaration of Conformity

We: Solid State Cooling Systems
 167 Myers Corners Road
 Wappingers Falls, NY 12590
 USA

declare under our sole responsibility that the

UC160-190 (formerly named "Oasis") - All Models

meets the provisions of the directives:

Emissions:

CFR Title 47 FCC Part 15 Subpart B, Class A
 ICES-003, Issue 6, Class A
 EN 61326-1: 2013 per EN 55011:2009 + A1: 2010 Group 1 Class A
 ACMA AS/NZS CISPR 11:2009 + A1:2010

Immunity:

EN 61326-1: 2013 Electrical Equipment for Measurement, Control, and Laboratory Use - EMC
 EN 61000-3-2 Harmonics Emissions
 EN 61000-3-3 Voltage Fluctuations and Flicker
 EN 61000-4-2 Electro-Static Discharge
 EN 61000-4-3 Radiated Radio Frequency (RF) Immunity
 EN 61000-4-4 Electrical Fast Transient/Burst Immunity
 EN 61000-4-5 Surge Immunity
 EN 61000-4-6 Conducted RF Disturbance Immunity
 EN 61000-4-11 Voltage Dips, Interruptions and Short Variations
 EN 61000-6-2 Electromagnetic Compatibility Part 6-2: Immunity for Industrial Environments

Safety:

EN 61010-1: 2010 3rd Edition Low Voltage Directive Safety requirements for electrical
 UL 61010-1: 2012 equipment for measurement, control, and laboratory use.
 CAN/CSA C22.2 No. 61010-1 2012

Lloyd F Wright Chief Technology Officer	
Date	January 16, 2018

SAFETY PRECAUTIONS AND SYMBOLS



Read the SDS for the coolant used and follow **all** safety precautions listed in the SDS prior to removing coolant tubes or opening the fill cap as this could result in contact with the coolant inside.



Caution! Risk of electric shock. Disconnect the power cord prior to servicing. This includes opening the cover for any reason.

CAUTION

- * Never disassemble the chiller as irreparable damage may occur.
 - * Never store the chiller over 60 °C.
 - * Never operate the chiller in ambient temperatures of 40 °C or greater.
 - * Never operate the chiller within 2 °C of the coolant's freezing point.
 - * Never use alcohol (methanol, ethanol or isopropanol) based coolants.
 - * Always use only proper coolants as specified in manual. Solid State Cooling Systems recommends Koolance LIQ-702CL-B (27% propylene glycol and water)
 - * Never ship the chiller with coolant inside the liquid cold plate as freezing temperatures may be encountered which would damage the unit. Always pump all coolant out of the chiller prior to shipping.
 - * Always match wetted materials (metal) to the wetted materials in your system. If your system has aluminum cold plates/tubing, use the standard UC160-190. If your system has copper cold plates/tubing, select the UC160-190 copper models. Stainless steel may be used with either material.
-

Symbols Used in this Manual



CAUTION

The red CAUTION equilateral triangle symbol appears throughout the manual. Please follow the important instructions accompanying this symbol to avoid significant damage to the chiller.



WARNING

The red WARNING equilateral triangle symbol appears throughout the manual accompanying certain maintenance and repair activities. Please follow the important instructions accompanying this symbol to avoid situations that could cause injury to the operator or other personnel.

**PRODUCT MANUAL****UC160/UC170/UC180/UC190****THERMOELECTRIC CHILLER****SECTION 1****INTRODUCTION**

The "Ultra Compact" UC160-190 recirculating chiller (formerly named "Oasis") utilizes thermoelectric technology to deliver between 160 and 190 Watts of cooling capacity without the use of compressors or refrigerants. With fewer moving parts, the system is highly reliable and energy efficient.

As the world's smallest, air cooled recirculating chiller, UC160-190 is the ideal solution for a variety of applications, including precision lasers, analytical equipment, medical equipment, lab equipment, low-light CCD cameras, microtiter testing, or any other application requiring precise, point of use temperature control. UC160-190 provides 500 ml/min of constant temperature coolant with a stability of $\pm 0.1^{\circ}\text{C}$.

The system is versatile and simple to operate. It also has a cycling feature where two different temperature set points may be entered with a soak time at each temperature and the number of cycles desired.

The chiller ships with the items listed below. Please locate them prior to discarding the shipping box.

- (1) UC160-190 Recirculating Liquid Chiller
- (1) 200 watt 13.5 VDC Table Top Power Supply
- (1) AC Line Cord
- (1) 250 ml Squirt Bottle
- (2) Valve quick disconnect fittings, 1/8th inch hose barb

SECTION 2

SPECIFICATIONS

Operating Range (Set Point):	Model UC160 or UC180: 2°C to 45°C Model UC170 or UC190: 10°C to 45°C
Ambient Temperature Range:	10°C to 40°C non-condensing
Stability / Repeatability:	±0.1°C with constant load (even near ambient)
Cooling Capacity (typical ¹):	Model UC160: 160 Watts @ 20°C in 20°C ambient air Model UC170: 170 Watts @ 20°C in 20°C ambient air Model UC180: 180 Watts @ 20°C in 20°C ambient air Model UC190: 190 Watts @ 20°C in 20°C ambient air
Noise Level (at 1 meter):	< 63 dBA
Coolant / Process Fluid:	Koolance (27% propylene glycol / water mix) or 27-50% ethylene glycol / water mix (contact SSCS for advice on other fluids)
Process Fluid Fittings:	1/8" female CPC quick connect with shut-off valve
Process Fluid Flow Rate:	~0.45 lpm @ 10 psi
Pump Options:	G3: Long life 500 ml/min @ 10 psig magnetically coupled gear pump G1: Original gear pump with 450 ml/min @ 10 psig flow
Tank Volume:	75 ml with level sensor (optional sealable tank cap)
Wetted Materials:	Aluminum + polymers or Copper + polymers
Dimensions (L x W x H):	7.5" x 5" x 7" (19cm x 13cm x 18cm)
Weight:	8 lbs (3.5 kg) [10 lbs (4.5 kg) with copper]
Power Input (external supply):	Universal: 100-240 VAC, 50/60 Hz, 2.8 amps max
Electrical Connections:	Plug in AC adaptor on 2 pin male connector
Power Consumption:	less than 200 Watts
Operating Voltage:	13.5 VDC, 15 amps max (less than 200W power consumption)
Controls:	Digital PID controller for heating and cooling
Communications:	Keypad or RS232 interface
Alarms	Temperature, fluid level, system or component failure (display, RS232 and dry contact)
Standards	TUV listed to UL, CAN/CSA and EN 61010-1, CE 61010-1, (optional upgrade for RoHS compliance)
Warranty	1 year

Note 1: Cooling capacities shown are typical. Actual cooling capacity may vary with configuration.

Figure 1
UC160-190 Cooling Capacity in 20°C Ambient

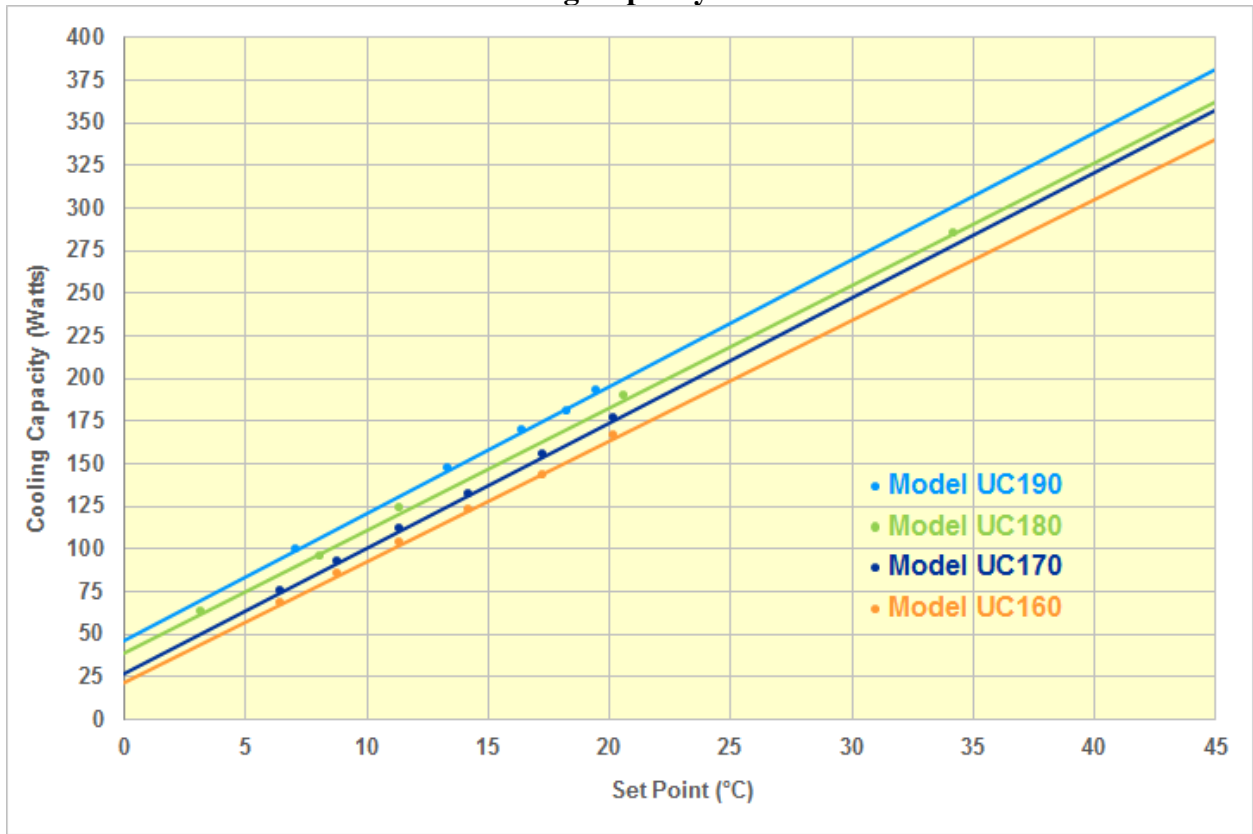
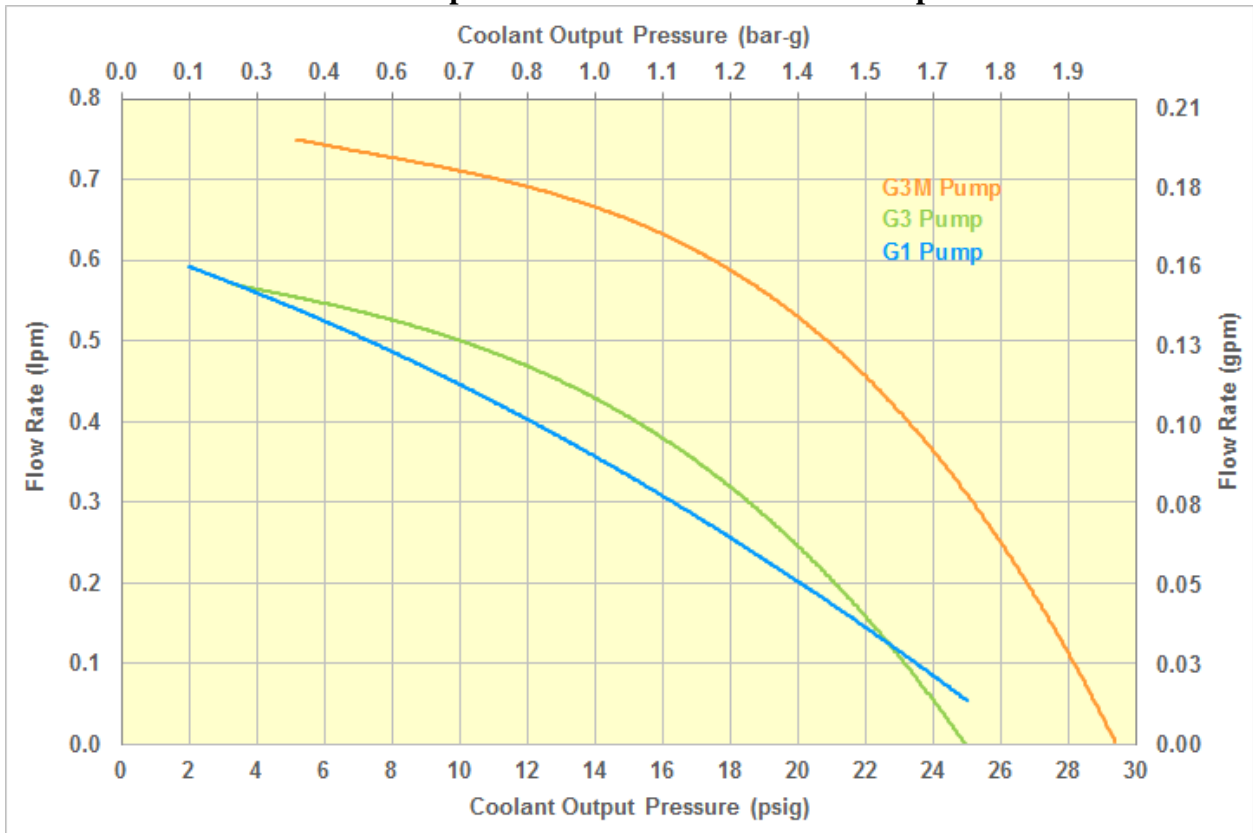

Figure 2
UC160-190 Pump Performance @ 20°C Fluid Temperature



Note: Pump to pump variation is +/- 10%.

SECTION 3 HOOK UP

Figure 3A: Top View



Figure 3B: Back View

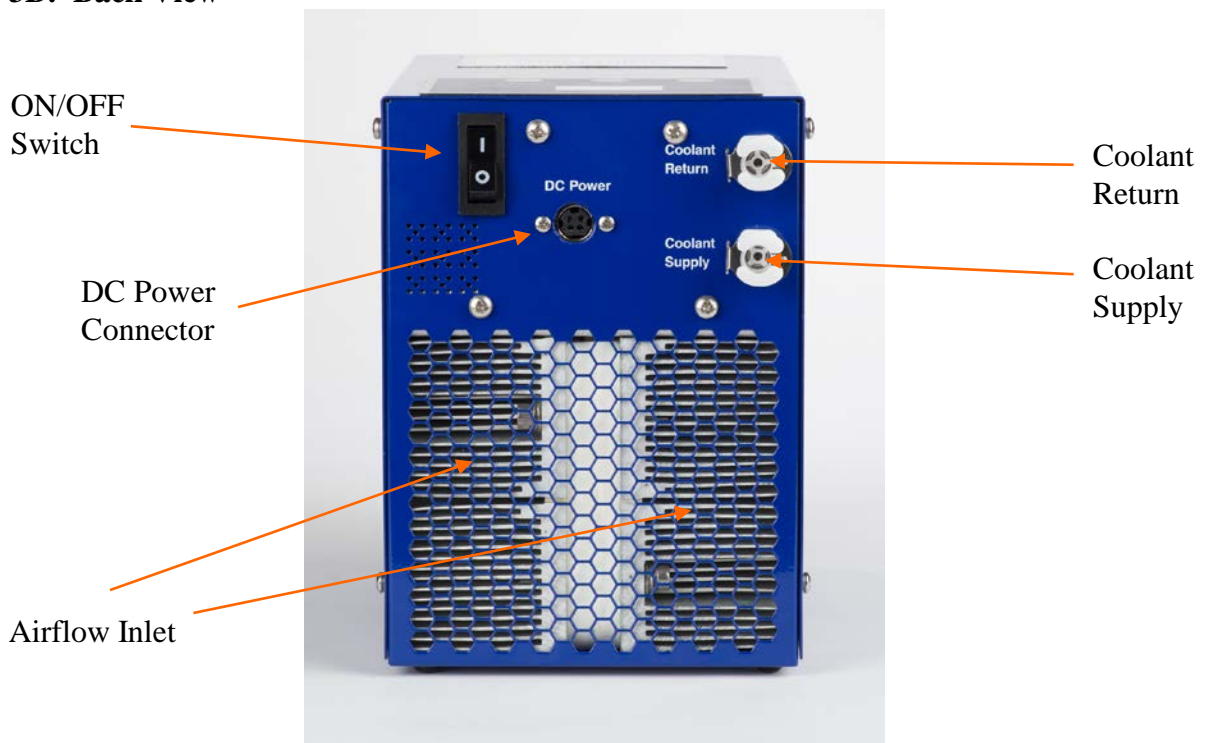

3.1 ELECTRICAL CONNECTIONS (SEE FIGURES 3A AND 3B)



WARNING

Electrical Shock
Hazard: Never Plug
in a Line Cord with
Wet Hands

Power: UC160-190 comes with a 200w 13.5VDC bench top power supply. Plug the DC output connector into the UC160-190 as shown in figure 3B.

The Kycon KPPX-4P has the following pin configuration:

Pin 1	13.5 VDC (+)
Pin 2	13.5 VDC (-)
Pin 3	13.5 VDC (+)
Pin 4	13.5 VDC (-)

A wide variety of power cords are available to support universal power operation:

Code	Country / Region	Part Number
-P1	USA/Canada	22-22333-1
-P2	Europe	22-22333-2
-P3	Japan	22-22333-3
-P4	UK	22-22333-4
-P5	Israel	22-22800-1
-P6	Australia	22-23213-1
-P7	Korean	22-23526-1
-P8	China (3 prong)	22-23661-1
-P9	Brazil	22-25122-1
-P10	India/South Africa Type D - 5A	16-23918-1
-P11	India/South Africa Type M - 15A	16-23918-2
-P20	IEC C13 to C14 39"	22-26026-1

Alarms: UC160-190 has one 250 VAC 1 amp dry contact relay to indicate a system alarm or temperature out of range. Connect to this dry contact on the 9-pin dsub connector as follows:

System/Temp Alarm: Pin 1
Alarm Signal Return: Pin 6

RS 232: UC160-190 comes with a RS-232 communication link. See Section 7 for details on the RS-232 connections and protocol.

3.2 PLUMBING CONNECTIONS (SEE FIGURE 3A AND 3B)



CAUTION

Always match wetted materials to avoid potentially corroding your system or clogging the cold plates

The UC160-190 has two Colder Products compatible 1/8" valved quick disconnect coolant fittings. Two mating valved quick disconnect inserts are included with 1/8" ID hose barb fittings for convenience.

IMPORTANT NOTE: Always match wetted materials (metal) to the wetted materials in your system. If your system has aluminum cold plates/tubing, use the standard UC160-190. If your system has copper cold plates/tubing, select the UC160-190 copper models. Stainless steel may be used with either material. Using copper/brass and aluminum in the same system with water coolants may result in corroded metals and clogging of the cold plates in the UC160-190 unit or system being controlled.

3.3 AIR CONSIDERATIONS

Restricting airflow into or out of the UC160-190 unit will impair performance. Maintain at least 3" of clearance around the air inlet and outlet to ensure no restriction of airflow.

3.4 COOLANT FILL



WARNING

Read the Coolant SDS
Prior to filling the chiller

The coolant fill cap (or optional sealable tank plug) is located at the top of the unit under the cover magnet. To open the yellow cap just lift the strap then use the 250 ml bottle (shipped with the chiller) to fill reservoir prior to starting unit. Turn on the UC160-190 chiller and add additional coolant as necessary to maintain the liquid level at the bottom of the tank neck.

For units with the sealable tank plug option, remove the cover magnet, twist the plug 90° and pull up to remove the plug. Fill the tank and then start the chiller. Allow the chiller to run 30 minutes with the plug removed, adding coolant as necessary to maintain the liquid level at the bottom of the tank neck. After 30 minutes carefully press the tank plug into the tank neck keeping the plug level, then twist the plug 90° under the cover and replace the magnet.

Solid State Cooling Systems recommends Koolance LIQ-702CL-B (27% propylene glycol and water) with corrosion inhibitors and algaecides. (Note: propylene glycol is non-toxic). This coolant has the added benefit of extending the UC160-190 chiller's pump life.



CAUTION

Use only recommended coolants

Ethylene glycol/water mixtures are also acceptable as coolants. Note that algae growth can occur when water is used without at least 25% propylene or ethylene glycol.

IMPORTANT NOTE: Use of methanol, ethanol or isopropanol as coolants, either by themselves or in water mixtures will damage the UC160-190 pump.

3.5 PRIMING THE PUMP

Normally, the UC160-190 pump primes immediately upon power up. Occasionally at initial start-up, or when starting up the UC160-190 after not having run for a long period of time, the UC160-190 pump will not prime and no coolant will flow out. If this occurs, use the following procedure to prime the pump:

Coolant Supply Fitting



- 1) Turn off the UC160-190 chiller.
- 2) Disconnect the Coolant Supply line.
- 3) Create a drain tube by pushing a piece of 1/8" ID tubing onto one of the 1/8" quick disconnect fittings supplied with the UC160-190 chiller. This tube needs to be long enough for coolant to be pumped into a bucket or other collection container.
- 4) Plug this drain tube into the coolant supply quick disconnect fitting.
- 5) Holding the tank lid open, turn on the UC160-190 chiller until coolant begins to come out of the drain tube, and then turn the UC160-190 chiller off.
- 6) Replace the drain tube with your coolant line disconnected in step 2. The UC160-190 pump is now primed and ready for operation.

SECTION 4

START UP



WARNING

Electrical Shock Hazard:
Never Plug in a Line Cord
with Wet Hands

Start-up the chiller using the following steps:

- 1) Connect 1/8" ID hose to fluid connections located on the back side, labeled Coolant Supply and Coolant Return.
- 2) Open the reservoir cap on top (or remove optional sealable plug). Using the 250 ml bottle provided, fill the reservoir to just below the bottom of its neck with coolant.
- 3) Plug in the 13.5 VDC table top power supply or connect 13.5 VDC power to the DIN connector (wired as shown in section 3.1).
- 4) Optional: connect the alarm signal to the 9-pin dsub connector as shown in section 3.1.
- 5) Turn on switch located to the left of the display. The front display should read the current coolant temperature. If the front display reads "TANK LOW", add coolant to the reservoir until the display changes to read the coolant temperature.

Important Notes:

- 1) The UC160-190 system performs a self-diagnostic check for 10 seconds after turn-on. If the tank level low alarm persists, or if another alarm is displayed, consult section 6.0 of this manual.
- 2) If the chiller tank is filled above the bottom of its neck, coolant can leak out the top when the cap is closed (unless the optional sealable tank plug is being used).

SECTION 5

OPERATION

The chiller is operated via the control panel located on the top of the unit. The control panel has an 8-character LCD display and three input keys: UP, DOWN, and ENTER. These keys work as follows:

Key	Action
UP	Pressing the UP key raises the parameter value displayed.
DOWN	Pressing the DOWN key lowers the parameter value displayed
ENTER	Pressing the ENTER key momentarily enters the parameter changed.
ENTER	Pressing and holding the ENTER key for 3 seconds changes the LCD display menu.

5.1 SIMPLE OPERATION

UC160-190 comes with preset operating parameters that will work well for most applications. If temperature control at one temperature is desired, follow the steps below.

- 1) Turn on chiller and wait for display to read TEMP: XX.X°C
- 2) Press the UP or DOWN keys to change SETTEMP1 to the desired set point.
- 3) Press the ENTER key.

The chiller will now control to the set point temperature. To change the set point temperature just press the UP or DOWN keys again to change SETTEMP1 to the new set point, followed by the ENTER key.

5.2 ADVANCED OPERATION

UC160-190 has two menus: the Status Menu and the Parameter Input Menu. The Status Menu shows the current temperature of coolant leaving the chiller (see Figure 4). The Status Menu also allows input of new coolant temperature set points when the cycling feature is off. The Parameter Input Menu allows input of set point temperatures; soak times, number of cycles if cycling between two temperatures, an alarm temperature, a temperature offset, and a password to enter the Parameter Input Menu. (The default password is 0000 until changed by the user.) Press and hold the enter key for 3 seconds to enter the parameter menu.

Note: While in the Parameter Input Menu, if no keys are pressed for 30 seconds the display will revert to the status menu.

Figure 4: MENU STRUCTURE:

NOMENCLATURE:

▲UP or Increase Value

▼Down or Decrease Value

↵ Press Enter Momentarily

—————→ Press & Hold Enter Key 3 Sec

SIMPLE OPERATION (STATUS MENU)		ADVANCED OPERATION (PARAMETER INPUT MENU)
TEMP: XX.X°C (current temp)	press and hold enter key —————→	PASSWORD XXXX (see notes 1+2)
PRESS ▼OR ▲ (change set point)		↵
SETTEMP1 XX.X°C		SETTEMP1 XX.X°C
↵		↵
TEMP: XX.X°C (current temp)		SETTIME1 XXXX (in minutes ⁴)
		↵
		SETTEMP2 XX.X°C
		↵
		SETTIME2 XXX (in minutes ⁴)
		↵
		# CYC XXX (see note 3)
		↵
		ALRM TMP +/-X.X°C
		↵
		OFFSET +/-X.X°C
		↵
		CHNG PWD Y/N (change password)

Allowable Value Ranges:

	MODEL UC160 OR 180	MODEL UC170 OR 190
SETTEMP1	2 TO 45 °C	10 TO 45 °C
SETTIME1	0 TO 999 minutes	
SETTEMP2	2 TO 45 °C	10 TO 45 °C
SETTIME2	0 TO 999 minutes	
# OF CYC	0 TO 999	
ALRM TMP	1 TO 9 °C in 0.1°C increments	
OFFSET	-5 °C TO 5 °C in 0.1°C increments	
CHNG PWD	Y OR N	

NOTES:

1. When entering the PASSWORD, enter one digit at a time
2. The default password is 0000, until changed by the user
3. If continuous control at one set-point temperature is desired, set # OF CYCLES to zero.
4. Time units may be preset or reset to seconds or hours (contact SSCS for instructions how)

Status Menu: The status menu displays the current coolant temperature in °C or will display an alarm type should an alarm occur. Pressing the UP or DOWN keys with # of cycles set to zero will change the set point temperature upon pressing the START key.

Parameter Input Menu: The parameter input menu allows input of operating temperatures, soak times, number of cycles desired, temperature units desired, time units desired, the alarm temperature range and an offset temperature to change the displayed temperature.

SETTEMP1 = Set point of first control temperature.

If # OF CYCLES is set to zero, this is the control temperature.

SETTIME1 = Soak time at temperature 1.

Not used if # OF CYCLES is set to zero.

SETTEMP2= Set point of second control temperature.

Not used if # OF CYCLES is set to zero.

SETTIME2 = Soak time at temperature 2.

Not used if # OF CYCLES is set to zero.

OF CYC = Number of cycles between temperature1 and temperature2. If set to zero, the chiller will control at temperature SETTEMP1.

ALRM TMP = +/- Alarm temperature set point.

If the current temperature is outside of the set point +/- the dry contact alarm will open.

OFFSET = Used to adjust the current temperature displayed.

Entering 5 °C will increase the displayed temperature by 5 °C.

Typically used to match temperatures with an external sensor.

Also adjusts RS-232 temperature reported.

CHG PWD = Y/N Entering Y allows user to change the password allowing entry into the parameter input menu.

5.3 ALARM SIGNAL

UC160-190 has one normally closed dry contact alarm for temperature out of range or system failure, located on pins 1 & 6 of the 9-pin dsub connector.

A list of system failures causing the dry contact alarm to open can be found in Section 6. In the event of a failure, the alarm type will be shown on the front display.

5.4 DRAIN PROCEDURE



WARNING

Read the Coolant SDS
prior to draining the
chiller

1. The use of chemical splash resistant gloves and eye protection is recommended
2. Insert the proper mating male fitting with approximately 12 inches of tubing attached into both the “**coolant supply**” and “**coolant return**” fittings on the back of the UC160-190 chiller.
3. Place the tubing attached to the “**coolant supply**” fitting into a container to catch the draining fluid.
4. While holding a finger over the end of the tubing attached to the “**coolant return**” fitting, Turn the unit on (making sure to hold the drain hose in place) and run for 5 seconds. (Note: this will create a vacuum to cause the fluid in the internal plumbing to be drained)
5. After 5 seconds, release finger from blocking the tube attached to the “coolant return” fitting and continue to run chiller until fluid stops draining.
6. When fluid stops draining, turn off unit.
7. Lift tank lid and inspect to make sure that most of the fluid is drained.
8. Dispose of the coolant in a manner consistent with local regulations.

SECTION 6

SYSTEM ALARMS/TROUBLESHOOTING



WARNING

Electrical Shock Hazard:
Always unplug the unit
before removing the cover.



WARNING

Do not attempt to service or
repair the unit beyond the
troubleshooting checks
described in this section
without first contacting
Solid State Cooling Systems

UC160-190 has two system alarms that when triggered will show on the display. When an alarm is displayed the system will not attempt to heat or cool the coolant.

TANK LOW: Liquid reservoir level is too low. *Unless filling for the first time, check all outside plumbing lines for leaks. Once all leaks are sealed, remove the cap (or plug) and add more process fluid until the alarm disappears. Note: If the tank becomes empty, the display may read “pump fail”.*

RTD OPEN or RTD SHORT: The temperature sensor has failed or its connector has come loose. *Contact SSCS for an RMA number to return the unit for RTD replacement.*

PUMP FAIL: The pump motor speed is not within normal limits, indicating no coolant is flowing and/or the pump is damaged. *Either the pump has failed, or the external coolant lines are blocked. Check that there are no obstructions/closed valves or kinks in the coolant lines. Also check that the coolant lines are fully inserted into the CPC shut-off fittings on the UC160-190 chiller. If the coolant lines are not blocked, contact SSCS for an RMA number to return the unit for pump replacement.*

IMPORTANT NOTE: The tank level low alarm will automatically reset when the tank is filled. The RTD failure alarm will not reset until the system power is turned off.

OTHER ISSUES:

COOLING CAPACITY INSUFFICIENT: *If the chiller is not providing sufficient cooling, check that the air inlet and outlet are not restricted and that the fan is running. If airflow is not restricted, contact SSCS technical support.*

RS-232 COMMUNICATION NOT WORKING: *If the RS-232 communications does not seem to be working try cycling the power to reset the communications. If the problem persists, call SSCS technical support 845-296-1300.*

SECTION 7

RS-232 COMMUNICATION

The UC160-190 chiller comes with a modified (pin-out) RS232 communication port. The chiller uses this port to communicate a comprehensive set of control parameters with a Host PC - these parameters are outlined in Section 7.2. This port is a 9-pin female d-sub connector and is found on the front of the chiller (see Figure 3A).

Note also that pins 1 and 6 on this port are connected to a dry contact relay and thus the RS-232 connecting cable must be customized. This relay is "closed" when the unit is functioning properly and the RTD temperature is within the Alarm Range. The relay is "open" when the RTD temperature is outside the Alarm Range or any other fault exists.

7.1 COMMUNICATION SPECIFICATION

Wiring: Proper wiring depends upon whether the equipment being cooled (the Host) is wired as Data Computer Equipment (DCE) or Data Terminal Equipment (DTE)

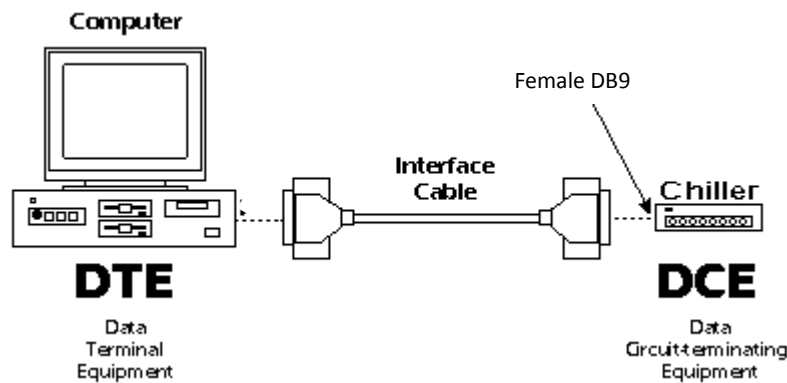

Table 1A: Signal definition and wiring for Host wired as DTE

Computer/Host/Master Male 9-Pin D-sub Pin #	Chiller / Slave Female 9-Pin D-sub Pin#
2 (Receive – RXD)	2 (Transmit – TXD)
3 (Transmit – TXD)	3 (Receive – RXD)
5 (Ground)	5 (Ground)

Note: Use a null modem cable if your RS-232 is set up as a DCE.

Specification

Speed:	9600 baud
Data Flow Control:	None
Data Format:	8-bit serial (Hex)
Number of Stop bits:	1
Parity:	None
Transmission Breakdown:	One command byte followed by zero, one, or two data bytes depending on the parameter.
Master/Slave:	UC160-190 is always the SLAVE (DTE)
Interrupts Reported:	None, must be polled for status
Transmission Length:	≤ 15 meters
Maximum Polling Frequency:	Two commands per second

7.2 COMMUNICATION PROTOCOL

Table 2: Command and Data Bytes (Hex)

	Bit Position	Description	Bit =1	Bit = 0
Command Byte	Bit 7 (MSB)	Set Remote Control	remote control	local control (chiller)
	Bit 6	Remote On/Off	chiller On	chiller in standby
	Bit 5	Communication Direction	remote to chiller (command from master)	chiller to remote (status from chiller)
	Bits 4 – 0	Parameters being communicated (see table 2)		
Data Bytes	1 or 2 bytes depending on parameter (see tables 3 and 4)			

Timing: UC160-190 can accept a maximum of two commands per second

Table 3: Control Parameter¹

Bits 4 – 0	Parameter	No of Data Bytes	Hex	
			Put	Get
00001	Chiller set point temperature	2	E1	C1
01001	Current temperature at chiller coolant output	2		C9
01000	Faults from chiller (fan, RTD failure, etc.)	1		C8
11110	% of Maximum thermoelectric power	3		DE
11111	Reset alarms and restart chiller	0	FF	

Notes: 1) UC160-190 echoes all commands prior to sending data or initiating an action; the first byte returned is always the command byte, followed by data byte(s) for GET commands.

Table 4: Temperature Data Bytes (2 bytes)

The 2 data bytes for the temperature set point and transmission of the current temperature represent the value of the temperature in 0.1°C increments. Data is transmitted Low Byte First, then High Byte

Temperature (examples)	Low Byte	High Byte	Hex
0.1 °C	00000001	00000000	01 00
1.0 °C	00001010	00000000	0A 00
10.0 °C	01100100	00000000	64 00
20.0 °C	11001000	00000000	C8 00
30.0 °C	00101100	00000001	2C 01
40.0 °C	10010000	00000001	90 01

Table 5: Faults Data Byte (1 byte)

0 = OK, 1 = Fault If multiple faults exist, more than one bit will =1

Bit Position	Fault Assigned	Hex value when fault is present
7 (MSB)	Temperature below alarm range	80
6	unassigned	N/A
5	Pump fault	20
4	RTD fault	10
3	unassigned	N/A
2	Temperature above alarm range	04
1	unassigned	N/A
0	Tank Level Low	01

Table 6: % TE Power Data Bytes (3 bytes)

The %TE power command returns three (3) data bytes, a sign byte that communicates heating or cooling, and two bytes of data from which the %TE power is calculated as follows:

Byte 1 = Mode, Cooling or Heating. If bit 7(MSB) = 0, then the system is cooling, if bit 7 = 1, then the system is heating. Ignore the remaining bits, they are arbitrary. (HEX<80 = cooling, HEX \geq 80 = heating)

Bytes 2 & 3 = %TE Power = $(61747 - (\text{Byte}2 + 256 * \text{Byte}3)) * 100 / 1235$

Mode	%TE Power	Byte 1 (Heat/Cool) Hex	LSByte 2		MSByte 3		Calculation
			Hex	Dec	Hex	Dec	
Cooling	10	<80	B7	183	F0	240	%TE= $(61747 - (183 + 256 * 240)) * 100 / 1235 = 10$
Cooling	25	<80	FE	254	EF	239	%TE= $(61747 - (254 + 256 * 239)) * 100 / 1235 = 25$
Heating	50	\geq 80	CA	202	EE	238	%TE= $(61747 - (202 + 256 * 238)) * 100 / 1235 = 50$
Heating	75	\geq 80	95	149	ED	237	%TE= $(61747 - (149 + 256 * 237)) * 100 / 1235 = 75$
Cooling	100	<80	60	96	EC	236	%TE= $(61747 - (96 + 256 * 236)) * 100 / 1235 = 100$

Notes

- 1) The UC160-190 handles RS232 bytes as they come in - i.e. it has no message data buffer. Therefore you must wait for a response from the UC160-190 – even if it's just a command echo acknowledge, before sending the next message.
- 2) An acknowledgement of the transmission will be sent back to the master when the UC160-190 reads the data. In the case of data transmitted to the UC160-190 Controller only, the acknowledgement will be the command byte. In the case of data requested by the master, the acknowledgement will be the command byte plus the data byte(s) requested.
- 3) If RS-232 communications does not seem to be functioning, cycle the main power to reset.

7.3 RS232 COMMUNICATION EXAMPLES

Example	Communications Sequence
1) Send set point of 25°C to chiller	Host sends command byte = E1 (hex)
	Host sends LOW data byte = FA (hex)
	Host sends HIGH data byte = 00 (hex)
2) Read chiller set point	Chiller sends command byte = E1 (hex)
	Host sends command byte = C1 (hex)
	Chiller sends command byte = C1 (hex)
3) Read the actual temperature	Chiller sends LOW data byte = set point value in hex (LB)
	Chiller sends HIGH data byte = set point value in hex (HB)
	Host sends command byte = C9
4) Read the faults table	Chiller sends command byte = C9
	Chiller sends LOW data byte = actual temp in hex (LB)
	Chiller sends HIGH data byte = actual temp in hex (HB)
5) Reset Alarms/Restart Chiller	Host sends command byte = C8
	Chiller sends command byte = C8
	Chiller sends faults data byte = fault data in hex
6) Read % TE Power	Host sends command byte = FF
	Chiller sends command byte FF
	Host sends command byte DE
6) Read % TE Power	Chiller sends command byte DE
	Chiller sends heating/cooling data byte <80=cool, >80=heat
	Chiller sends Low data byte = decimal used to calculate %TE
	Chiller sends High data byte = decimal used to calculate %TE

SECTION 8 TECHNICAL SUPPORT

Delighting our customers is our highest priority. Please contact us immediately for technical assistance whenever you have questions or concerns.

Hours: 8 a.m. to 5 p.m. Eastern Time, weekdays

Telephone: (845) 296-1300

Fax: (845) 296-1303

E-mail: info1@sscooling.com

SECTION 9

SDS FOR COOLANTS

9.1 KOOLANCE (27% PROPYLENE GLYCOL/WATER)



Safety Data Sheet – Last updated May 2016

1. IDENTIFICATION

Product: LIQ-702xx Coolant Fluid ("xx" signifies liquid color)

Manufacturer: Koolance Korea

Address: Koolance Bld, 40, Deokcheon-ro 34, Manan-gu, Anyang-si, Gyeonggi-do, Korea 14088

Telephone: (U.S.) +01 253-249-7669, Fax: (U.S.) +01 253-249-7453

Appearance: Liquid for cooling systems. Available in various colors and shipped in plastic bottles or containers.

Usage: For use in cooling systems only. Do not use in foodstuffs, beverages, or in other applications.

2. HAZARD IDENTIFICATION

Globally Harmonized System of Classification and Labeling of Chemicals (GHS)

- Physical Hazard: Not applicable
- Health Hazard: Skin Irritation – Category 2
Eye Irritation – Category 2
- Environmental Hazard: Not applicable

Label elements including precautionary statements.

Symbol:

Signal word: Warning



Hazard statement: H315 – May cause irritation to the skin.

H319 – May cause serious irritation to the eyes.

Prevention: P264 - Wash thoroughly after handling

P280 - Wear protective gloves, clothing, and eye protection.

Responses:

- P302+P352 If on skin: Wash exposure area with plenty of water and soap.
- P305+P351+P338 If in eyes: Rinse continuously with water for several minutes. Remove contact lenses if present and easy to do so. Continue rinsing.
- P337+P313: If skin or eye irritation persists, seek medical attention immediately.
- P362: Remove contaminated clothing and wash before reuse.

Storage / Disposal: P501: Refer to all federal, provincial, state, and local regulation prior to disposition of container and unused contents by reuse, recycle, or disposal.

NFPA Rating (estimated)

Health: 1

Flammability: 1

Reactivity: 0

Water Reactivity: 0



3. COMPOSITION / INFORMATION ON INGREDIENTS

Ingredients	CAS No.	EINECS No.	Conc. %
Distilled Water	7732-18-5	231-791-2	70 – 75
Propylene glycol	57-55-6	200-338-0	25 – 30
Others (Proprietary)	-	-	0.2 – 2.0

4. FIRST AID MEASURES

- In case of eye contact: Rinse thoroughly with plenty of water for at least 20 minutes. If irritation remains, consult a medical doctor immediately.
- In case of skin contact: Remove contaminated clothing. Wash with soap and plenty of water for at least 20 minutes. If irritation remains, consult a medical doctor immediately.
- If inhaled: Move person to fresh air. If not breathing, give artificial respiration and immediately contact emergency medical assistance.
- If ingested: Never give anything by mouth to an unconscious person. Rinse mouth with water and consult a medical doctor immediately.

Other medical attention: Medical persons should be aware of protective measures for handling.

Potential health effects: May be harmful or fatal if swallowed.

5. FIRE-FIGHTING MEASURES

- Flash Point: 118°C (Cleveland open cup)
- Suitable extinguishing media: Water spray, alcohol-resistant foam, dry chemical, carbon dioxide
- Specific hazards arising from the chemical: No data available
- Special protective equipment for fire fighters:
 - Use water spray to cool unopened containers.
 - Fire fighters should enter area wearing respiratory protection and protective equipment.

6. ACCIDENTAL RELEASE MEASURES

Personal Precautions:

- Ensure adequate ventilation.
- Remove all sources of ignition.
- Avoid contact with skin and eyes.
- Avoid inhalation of vapor, mist, or gas.

Environmental Precautions:

- Follow local regulations.

Methods and materials for containment and clean-up:

- Collect with non-combustible absorbent materials (sand and soil).

7. HANDLING AND STORAGE

Precautions for safe handling:

- Wear protective gloves, clothing, and eye/face protection.
- Do not spray on an open flame or other ignition source.
- Provide forced air ventilation in tanks and confined spaces.
- Avoid contact with skin and eyes.
- Avoid inhalation of vapor, mist, or gas.
- Keep away from sources of ignition. No smoking.

Conditions for safe storage:

- Keep container tightly closed.
- Keep in a dry and well-ventilated place.
- Keep cool.
- Avoid direct sunlight, heat sources, and strong oxidizing agents.

8. EXPOSURE CONTROL / PERSONAL PROTECTION

Conditions for safe storage:

- KOSHA: No data available
- US ACGIH: No data available

Appropriate engineering controls:

- Respiratory protection: Approved respirator equipped with cartridge for organic vapors
- Eye protection: Protective goggles
- Hand protection: Chemical resistant gloves

9. PHYSICAL AND CHEMICAL PROPERTIES

- State: Liquid at 20°C
- Flash Point: 118°C (Cleveland open cup). No flash occurred under 93°C (Tag closed cup)
- pH: 7.0 – 8.0 at 20°C; Sample H₂O = 1:5 (V/V)
- Viscosity: 2.3 mPa x s (cP) at 20°C
- Density: 1.03 at 20°C
- Water solubility: Soluble at 20°C
- Explosive properties: No self-reaction hazard; UN TDG test & criteria – Test E3
- Autoignition temperature: No spontaneous combustion under 300°C
- Boiling point (initial): >98°C
- Melting range: No data available
- Vapor pressure: No data available
- Oxidizing properties: No data available
- Partition coefficient (n-octanol/water): No data available
- Evaporation rate: No data available
- Decomposition temperature: No data available
- Lower explosion limit / Upper explosion limit: No data available

10. STABILITY AND REACTIVITY

Chemical stability:

Stable under recommended storage conditions.

Conditions to avoid:

Direct sunlight, heat, flames, and sparks.

Materials to avoid:

Strong oxidizing agents.

Hazardous decomposition products:

Carbon oxides

11. TOXICOLOGICAL INFORMATION

- Acute toxicity (Calculated):

Oral	rat	LD50 : 23,779 mg/kg
Skin	rabbit	LD50 : 38,021 mg/kg
Inhalation	rat	LC50 : 145 mg/kg
- Skin irritation: Irritating (Calculated, Category 2)
- Eye irritation: Irritating (Calculated, Category 2)
- Respiratory sensitization: No data available
- Skin sensitization: No data available
- Germ cell mutagenicity: No data available
- Carcinogenicity: Not classifiable; from IARC / EC ESIS
- Reproductive Toxicity: No data available
- Specific target organ toxicity – single exposure (GHS): No data available
- Specific target organ toxicity – repeated exposure (GHS): No data available
- Aspiration hazard: No data available

12. ECOLOGICAL INFORMATION

- Acute toxicity (Calculated):

Fish	LC50 : 8,700mg/l 96hr Pimephales promelas
Crustacean	LC50: 7,921mg/l 48hr Daphnia magna
Bird	EC50: 1,634mg/l 72hr Selenastrum capricornutum
- Persistence and degradability: No data available
- Bioaccumulative potential: No data available
- Mobility in soil: No data available
- Other adverse effects: No data available

13. DISPOSAL CONSIDERATIONS

Disposal consideration:

Observe all environmental regulations.

Disposal precaution:

Avoid disposing in the environment.

14. TRANSPORT INFORMATION

- TSCA: All ingredients are listed on the TSCA inventory
- DOT Classification: Not a DOT controlled material (U.S.)
- UN TDG: Not dangerous goods
- IMDG: Not dangerous goods
- IATA: Not dangerous goods
- Marine pollution: Not applicable
- Special precaution:
 - Fire EmS Guide: F-E (Recommendation)
 - Spillage EmS Guide: Not dangerous goods

15. REGULATORY INFORMATION

- Korea Industrial Safety and Health Act (GHS): Eye irritation – Category 2
- Korea Industrial Safety and Health Act (GHS): Skin irritation – Category 2
- Korea Hazardous Materials Safety Control Act: Not hazardous material
- Korea Toxic Chemicals Control Act: Not a toxic chemical
- Korea Persistent Organic Pollutants Control Act: Not applicable
- US OSHA Hazards (GHS): Eye irritation
- US OSHA Hazards (GHS): Skin irritation

16. OTHER INFORMATION

Last Updated: March, 2015

References:

- GHS Classification: EC ESIS, US NLM
- Physical and chemical properties: EC ESIS, US NLM
- Transport information: EC ESIS, US NLM
- Toxic and ecological information: OECD SIDS, IUCLID, US NLM, IARC, EC ESIS, CCRIS

Acronyms and Websites:

- EC ESIS : European chemical Substances Information System, <http://esis.jrc.ec.europa.eu/>
- IUCLID : International Uniform Chemical Information Database, <http://esis.jrc.ec.europa.eu/>
- US NLM : U.S. National Library of Medicine, <http://chem.sis.nlm.nih.gov/chemidplus/>
- HSDB : US Hazardous Substances Data Bank, <http://toxnet.nlm.nih.gov/>
- CCRIS : US Chemical Carcinogenesis Research Information System, <http://toxnet.nlm.nih.gov/>
- IARC : International Agency for Research on Cancer, <http://monographs.iarc.fr>

This SDS is composed with reference to documents and criteria provided by KOSHA. The information above is believed to be accurate and represents the best information currently available to us. However, we make no warranty of merchantability or any other warranty, express or implied, with respect to such information, and we assume no liability resulting from its use. Users should make their own investigations to determine the suitability of the information for their particular purposes. In no event shall Koolance be liable for any claims, losses, or damages of any third party or for lost profits or any special, indirect, incidental, consequential or exemplary damages, howsoever arising, even if Koolance has been advised of the possibility of such damages.

9.2 ETHYLENE GLYCOL

ThermoFisher
S C I E N T I F I C

SAFETY DATA SHEET

Creation Date: 02-Feb-2010

Revision Date: 17-Jan-2018

Revision Number 4

1. Identification

Product Name Ethylene glycol

Cat No. : E177-4; E177-20

CAS-No 107-21-1

Synonyms Monoethylene glycol; 1,2-Ethanediol

Recommended Use Laboratory chemicals.

Uses advised against Not for food, drug, pesticide or biocidal product use

Details of the supplier of the safety data sheet

Company

Fisher Scientific
One Reagent Lane
Fair Lawn, NJ 07410
Tel: (201) 796-7100

Emergency Telephone Number

CHEMTRECO, Inside the USA: 800-424-9300
CHEMTRECO, Outside the USA: 001-703-527-3887

2. Hazard(s) Identification

Classification

This chemical is considered hazardous by the 2012 OSHA Hazard Communication Standard (29 CFR 1910.1200)

Acute oral toxicity	Category 4
Specific target organ toxicity (single exposure)	Category 3
Target Organs - Central nervous system (CNS).	
Specific target organ toxicity - (repeated exposure)	Category 2

Label Elements

Signal Word

Warning

Hazard Statements

Harmful if swallowed
May cause drowsiness or dizziness
May cause damage to organs through prolonged or repeated exposure



Precautionary Statements

Prevention

Wash face, hands and any exposed skin thoroughly after handling
 Do not eat, drink or smoke when using this product
 Do not breathe dust/fume/gas/mist/vapors/spray
 Use only outdoors or in a well-ventilated area

Response

Get medical attention/advice if you feel unwell

Inhalation

IF INHALED: Remove victim to fresh air and keep at rest in a position comfortable for breathing
 Call a POISON CENTER or doctor/physician if you feel unwell

Ingestion

IF SWALLOWED: Call a POISON CENTER or doctor/physician if you feel unwell
 Rinse mouth

Storage

Store in a well-ventilated place. Keep container tightly closed
 Store locked up

Disposal

Dispose of contents/container to an approved waste disposal plant

Hazards not otherwise classified (HNOC)

WARNING. Reproductive Harm - <https://www.p65warnings.ca.gov/>.

3. Composition/Information on Ingredients

Component	CAS-No	Weight %
Ethylene Glycol	107-21-1	>95

4. First-aid measures

Eye Contact	Rinse immediately with plenty of water, also under the eyelids, for at least 15 minutes. Get medical attention.
Skin Contact	Wash off immediately with plenty of water for at least 15 minutes. Get medical attention immediately if symptoms occur.
Inhalation	Move to fresh air. Do not use mouth-to-mouth method if victim ingested or inhaled the substance; give artificial respiration with the aid of a pocket mask equipped with a one-way valve or other proper respiratory medical device. Get medical attention immediately if symptoms occur. If not breathing, give artificial respiration.
Ingestion	Do not induce vomiting. Call a physician or Poison Control Center immediately.
Most important symptoms and effects	Breathing difficulties.
Notes to Physician	Treat symptomatically

5. Fire-fighting measures

Suitable Extinguishing Media	Use water spray, alcohol-resistant foam, dry chemical or carbon dioxide.
Unsuitable Extinguishing Media	No information available
Flash Point	111 °C / 231.8 °F
Method -	DIN 51758
Autoignition Temperature	413 °C / 775.4 °F
Explosion Limits	
Upper	15.30 vol %
Lower	3.20 vol %
Sensitivity to Mechanical Impact	No information available
Sensitivity to Static Discharge	No information available

Specific Hazards Arising from the Chemical

Thermal decomposition can lead to release of irritating gases and vapors. Keep product and empty container away from heat and sources of ignition.

Hazardous Combustion Products

Carbon monoxide (CO) Carbon dioxide (CO₂)

Protective Equipment and Precautions for Firefighters

As in any fire, wear self-contained breathing apparatus pressure-demand, MSHA/NIOSH (approved or equivalent) and full protective gear.

NFPA

Health	Flammability	Instability	Physical hazards
2	1	1	N/A

6. Accidental release measures

Personal Precautions	Ensure adequate ventilation. Use personal protective equipment.
Environmental Precautions	Should not be released into the environment. See Section 12 for additional ecological information.
Methods for Containment and Clean Up	Soak up with inert absorbent material. Keep in suitable, closed containers for disposal.

7. Handling and storage

Handling	Wear personal protective equipment. Ensure adequate ventilation. Do not breathe vapors or spray mist. Avoid contact with skin, eyes and clothing.
Storage	Keep containers tightly closed in a dry, cool and well-ventilated place. Keep away from heat and sources of ignition.

8. Exposure controls / personal protection

Exposure Guidelines

Component	ACGIH TLV	OSHA PEL	NIOSH IDLH	Mexico OEL (TWA)
ethylene glycol	TWA: 25 ppm STEL: 50 ppm STEL: 10 mg/m ³	(vacated) Ceiling: 50 ppm (Vacated) Ceiling: 125 mg/m ³		Ceiling: 100 mg/m ³

Legend

ACGIH - American Conference of Governmental Industrial Hygienists

OSHA - Occupational Safety and Health Administration

Engineering Measures

Ensure adequate ventilation, especially in confined areas. Ensure that eyewash stations and safety showers are close to the workstation location.

Personal Protective Equipment**Eye/face Protection**

Wear appropriate protective eyeglasses or chemical safety goggles as described by OSHA's eye and face protection regulations in 29 CFR 1910.133 or European Standard EN166.

Skin and body protection

Wear appropriate protective gloves and clothing to prevent skin exposure.

Respiratory Protection

Follow the OSHA respirator regulations found in 29 CFR 1910.134 or European Standard EN 149. Use a NIOSH/MSHA or European Standard EN 149 approved respirator if exposure limits are exceeded or if irritation or other symptoms are experienced.

Hygiene Measures

Handle in accordance with good industrial hygiene and safety practice.

9. Physical and chemical properties

Physical State	Viscous liquid Liquid
Appearance	Colorless
Odor	Odorless
Odor Threshold	No information available
pH	5.5-7.5 50% aq. sol
Melting Point/Range	-13 °C / 8.6 °F
Boiling Point/Range	196 - 198 °C / 384.8 - 388.4 °F @ 760 mmHg
Flash Point	111 °C / 231.8 °F
Method -	DIN 51758
Evaporation Rate	No information available
Flammability (solid,gas)	Not applicable
Flammability or explosive limits	
Upper	15.30 vol %
Lower	3.20 vol %
Vapor Pressure	0.12 mmHg @ 20 °C
Vapor Density	2.14 (Air = 1.0)
Specific Gravity	1.113
Solubility	miscible
Partition coefficient; n-octanol/water	No data available
Autoignition Temperature	413 °C / 775.4 °F
Decomposition Temperature	> 500°C
Viscosity	21 cP (20°C)
Molecular Formula	C2 H6 O2
Molecular Weight	62.06

10. Stability and reactivity

Reactive Hazard	None known, based on information available
Stability	Hygroscopic.
Conditions to Avoid	Incompatible products. Excess heat. Exposure to moist air or water.
Incompatible Materials	Strong oxidizing agents, Strong acids, Strong bases, Aldehydes
Hazardous Decomposition Products	Carbon monoxide (CO), Carbon dioxide (CO2)
Hazardous Polymerization	Hazardous polymerization does not occur.
Hazardous Reactions	None under normal processing.

11. Toxicological Information

Acute Toxicity

Product Information Component Information

Component	LD50 Oral	LD50 Dermal	LD50 Inhalation
Ethylene glycol	7712 mg/kg (Rat)	9530 µL/kg (Rabbit) 10600 mg.kg (Rat)	Not listed

Toxicologically Synergistic Products No information available

Delayed and immediate effects as well as chronic effects from short and long-term exposure

Irritation May cause eye, skin, and respiratory tract irritation

Sensitization No information available

Carcinogenicity The table below indicates whether each agency has listed any ingredient as a carcinogen.

Component	CAS-No	IARC	NTP	ACGIH	OSHA	Mexico
Ethylene glycol	107-21-1	Not listed	Not listed	Not listed	Not listed	Not listed

Mutagenic Effects No information available

Reproductive Effects No information available.

Developmental Effects No information available.

Teratogenicity No information available.

STOT - single exposure Central nervous system (CNS)

STOT - repeated exposure Kidney Liver

Aspiration hazard No information available

Symptoms/effects, both acute & delayed No information available

Endocrine Disruptor Information No information available

Other Adverse Effects The toxicological properties have not been fully investigated.

12. Ecological Information

Ecotoxicity

Do not empty into drains.

Component	Freshwater Algae	Freshwater Fish	Microtox	Water Flea
Ethylene glycol	EC50: 6500 - 13000 mg/L, 96h (Pseudokirchneriella subcapitata)	LC50: = 16000 mg/L, 96h static (Poecilia reticulata) LC50: 40000 - 60000 mg/L, 96h static (Pimephales promelas) LC50: = 40761 mg/L, 96h static (Oncorhynchus mykiss) LC50: = 41000 mg/L, 96h (Oncorhynchus mykiss) LC50: 14 - 18 mL/L, 96h static (Oncorhynchus mykiss) LC50: = 27540 mg/L, 96h static (Lepomis macrochirus)	Not listed	EC50: = 46300 mg/L, 48h (Daphnia magna)

Persistence and Degradability	Persistence is unlikely
Bioaccumulation/ Accumulation	No information available.
Mobility	Will likely be mobile in the environment due to its water solubility.

Component	log Pow
Ethylene glycol	-1.93

13. Disposal considerations

Waste Disposal Methods	Chemical waste generators must determine whether a discarded chemical is classified as a hazardous waste. Chemical waste generators must also consult local, regional, and national hazardous waste regulations to ensure complete and accurate classification.
-------------------------------	---

14. Transport information

DOT	Not regulated
TDG	Not regulated
IATA	Not regulated
IMDG/IMO	Not regulated

15. Regulatory information

All of the components in the product are on the following Inventory lists: X = listed

International Inventories

Component	TSCA	DSL	NDSL	EINECS	ELINCS	NLP	PICCS	ENCS	AICS	IECSC	KECL
Ethylene glycol	X	X	-	203-473-3	-		X	X	X	X	X

Legend:

X - Listed

E - Indicates a substance that is the subject of a Section 5(e) Consent order under TSCA.

F - Indicates a substance that is the subject of a Section 5(f) Rule under TSCA.

N - Indicates a polymeric substance containing no free-radical initiator in its inventory name but is considered to cover the designated polymer made with any free-radical initiator regardless of the amount used.

P - Indicates a commenced PMN substance

R - Indicates a substance that is the subject of a Section 6 risk management rule under TSCA.

S - Indicates a substance that is identified in a proposed or final Significant New Use Rule

T - Indicates a substance that is the subject of a Section 4 test rule under TSCA.

XU - Indicates a substance exempt from reporting under the Inventory Update Rule, i.e. Partial Updating of the TSCA Inventory Data Base Production and Site Reports (40 CFR 710(B)).

Y1 - Indicates an exempt polymer that has a number-average molecular weight of 1,000 or greater.

Y2 - Indicates an exempt polymer that is a polyester and is made only from reactants included in a specified list of low concern reactants that comprises one of the eligibility criteria for the exemption rule.

U.S. Federal Regulations

TSCA 12(b) Not applicable

SARA 313

Component	CAS-No	Weight %	SARA 313 Threshold Values %
Ethylene glycol	107-21-1	>95	1.0

SARA 311/312 Hazard Categories See section 2 for more information

CWA (Clean Water Act) Not applicable

Clean Air Act

Component	HAPS Data	Class 1 Ozone Depletors	Class 2 Ozone Depletors
Ethylene glycol	X		-

OSHA Occupational Safety and Health Administration Not applicable

CERCLA This material, as supplied, contains one or more substances regulated as a hazardous substance under the Comprehensive Environmental Response Compensation and Liability Act (CERCLA) (40 CFR 302)

Component	Hazardous Substances RQs	CERCLA EHS RQs
Ethylene glycol	5000 lb	-

California Proposition 65 This product does not contain any Proposition 65 chemicals

U.S. State Right-to-Know Regulations

Component	Massachusetts	New Jersey	Pennsylvania	Illinois	Rhode Island
Ethylene glycol	X	X	X	X	-

U.S. Department of Transportation

Reportable Quantity (RQ): Y
 DOT Marine Pollutant N
 DOT Severe Marine Pollutant N

U.S. Department of Homeland Security

This product does not contain any DHS chemicals.

Other International Regulations

Mexico - Grade Slight risk, Grade 1

16. Other information

Prepared By Regulatory Affairs
 Thermo Fisher Scientific
 Email: EMSDS.RA@thermofisher.com

Creation Date 02-Feb-2010

Revision Date 17-Jan-2018

Print Date 17-Jan-2018

Revision Summary This document has been updated to comply with the US OSHA HazCom 2012 Standard replacing the current legislation under 29 CFR 1910.1200 to align with the Globally Harmonized System of Classification and Labeling of Chemicals (GHS).

Disclaimer

The information provided in this Safety Data Sheet is correct to the best of our knowledge, information and belief at the date of its publication. The information given is designed only as a guidance for safe handling, use, processing, storage, transportation, disposal and release and is not to be considered a warranty or quality specification. The information relates only to the specific material designated and may not be valid for such material used in combination with any other materials or in any process, unless specified in the text

End of SDS

WARRANTY POLICY

The UC160-190 Chiller is covered under a one-year parts and labor warranty from the date of shipment, assuming proper use and maintenance of the unit. All warranty work shall be performed at Solid State Cooling Systems' facility, currently located in Wappingers Falls, NY, USA and requires pre-authorization by SSCS. Malfunctioning products should be returned to Solid State Cooling Systems by the method described below. Solid State Cooling Systems will provide a Failure Analysis Report to the customer and will determine if the problem is covered under the warranty.

Warranty Coverage:

Products with defects in components or manufacturing which are reported to Solid State Cooling Systems before the end of the warranty period will be repaired or replaced at no cost (see below for reporting requirements). The warranty period begins on the date the product was initially shipped from Solid State Cooling Systems' factory.

Excluded from Warranty:

Excluded from warranty is any damage caused to the product occurring during, but not limited to, such events as shipment, installation, storage, or usage occurring during a situation specifically cautioned against or noted in the product manual.

Specific situations, which invalidate the warranty, include (but are not limited to):

- Operating the unit outside the stated specification ranges
- Removing the serial number label.
- Any disassembly (partial or complete) of the product.
- Changing any components of the product.
- Subjecting the product to temperatures below the freezing point of the coolant used.
- Subjecting any product to temperature, voltage, current, or pressure (internal or external) greater than that specified in the product manual.
- Any actions prohibited in the "Caution" section of the product manual.

Returned Goods Procedure and Reporting Requirements

Before a failed product is returned to the factory, a Returned Materials Authorization (RMA) number must be obtained from Customer Service at (845) 296-1300. The date the RMA is requested will be the reporting date noted and relevant to the warranty. Products, which have received an RMA, must be received at SSCS's factory, within 30 days or the reporting date will be moved ahead 30 days and a new 30-day waiting period will begin. Customers shall pay shipping cost of returning any unit to SSCS and SSCS shall pay shipping cost of returning any unit repaired under warranty to the customer.

All out of warranty returned goods will require an evaluation purchase order prior to receipt at Solid State Cooling Systems. The evaluation costs will depend on product model and will be deducted from the cost of any repairs required.